

Common designation: LD-1

IATA ULD code: AKC contoured container

Also known as: AVC, AVD, AVK, AVJ, and forkable AVY

Rate class: Type 8

Description: Half-width lower hold container with one angled side. Door is either canvas or solid.

Suitable for: **747, 767, 777, 787, MD-11 lower hold**

Door opening: 58 x 61-in (147 x 155-cm)

Maximum gross weight: 1,588 kg (3,501 lb)

Tare weight: 70 to 170-kg (155 to 375-lb)

AS1825 volume: 5.0 m³ (175 ft³)

Boeing volume: 5.0 m³ (175 ft³)

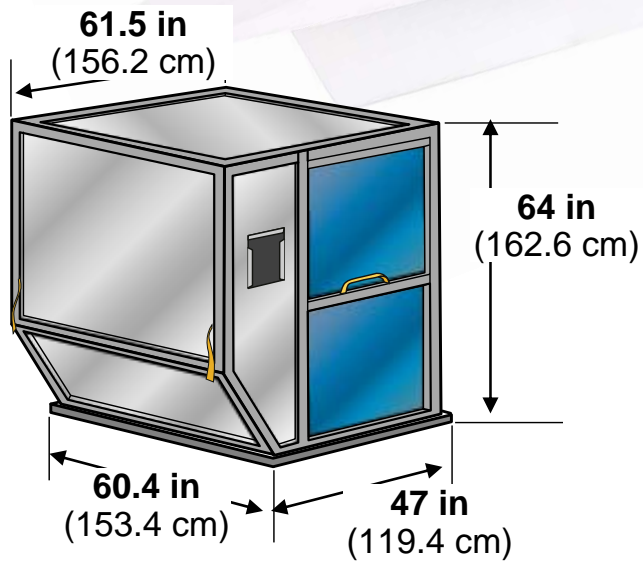

Common designation: LD-2

IATA ULD code: DPE contoured container

Also known as: APA, DPA, and forkable DPN

Rate class: Type 8D

Description: Half-width lower hold container with one angled side. Door is either canvas or solid.

Suitable for: **747, 767, 777, 787 lower hold**

Door opening: 44 x 60-in (112 x 152-cm)

Maximum gross weight: 1,225 kg (2,700 lb)

Tare weight: 92 kg (203 lb)

AS1825 volume: 3.5 m³ (124 ft³)

Boeing volume: 3.5 m³ (124 ft³)

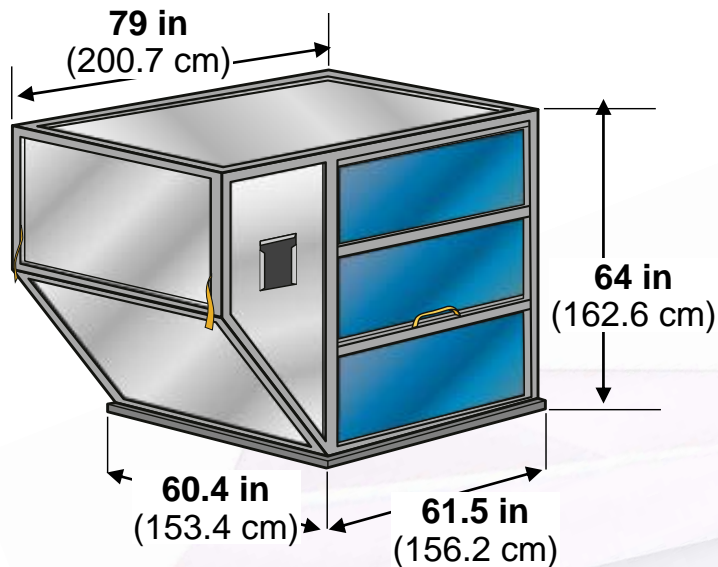

Common designation: LD-3

IATA ULD code: AKE contoured container
 Also known as: AKE, AVA, AVB, AVC, AVK, DVA, DVE, DVP, XKS, XKG, and forkable AKN, AVN, DKN, DVN, and XKN

Rate class: Type 8

Description: Half-width lower hold container with one angled side. Door is either canvas or solid.

Suitable for: **747, 767, 777, 787, DC-10, MD-11 lower hold**

Door opening: 58 x 61-in (147 x 155-cm)

Maximum gross weight: 1,588 cm (3,500 lb)

Tare weight: 82 kg (181 lb)

AS1825 volume: 4.5 m³ (159 ft³)

Boeing volume: 4.5 m³ (160 ft³)

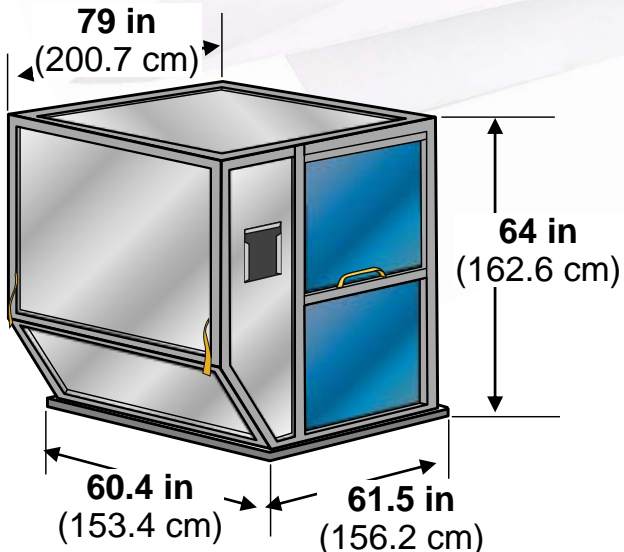

Common designation: LD-3 Reefer

IATA ULD code: RKN contoured cool container

Also known as: RVN

Rate class: Type 8

Description: Half-width lower hold insulated container with one angled end. Door is solid. Most examples are forkable.

Suitable for: **747, 767, 777, 787, DC-10, MD-11 lower hold**

Door opening: 54 x 55-in (137 x 140-cm)

Maximum gross weight: 1,588 cm (3,500 lb)

Tare weight: 210 kg (463 lb)

AS1825 volume: 4.5 m³ (159 ft³) plus internal volume (as is)

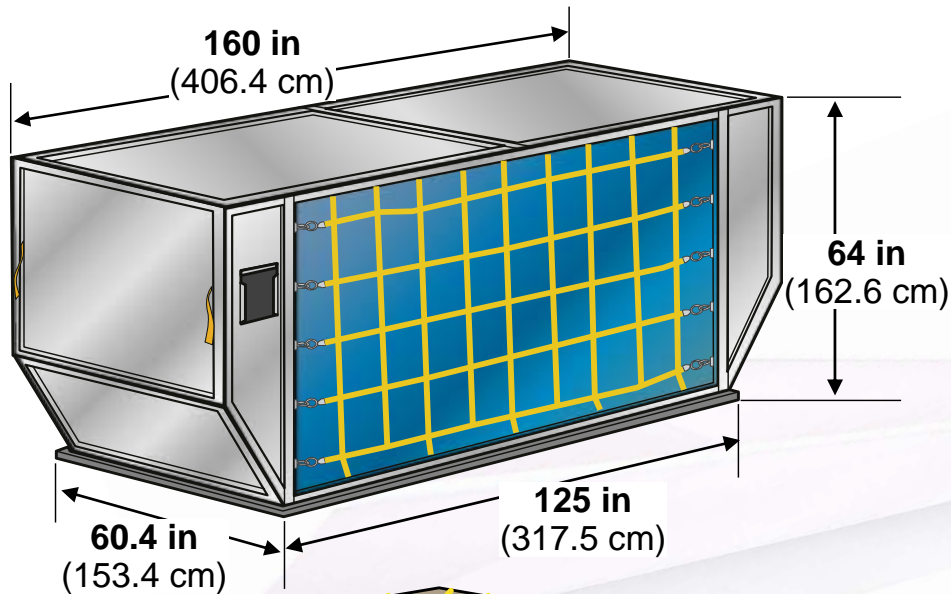

Common designation: LD-6

IATA ULD code: ALF contoured container

Also known as: AWA, AWF, and forkable AWC

Rate class: Type 6W

Description: Full-width lower hold container with angled ends.

Door is canvas with built-in door straps.

Suitable for: **747, 777, 787, DC-10, MD-11 lower hold**

Door opening: 120 x 60-in (305 x 152-cm)

Maximum gross weight: 3,175 kg (7,000 lb)

Tare weight: 230 kg (507 lb)

AS1825 volume: 9.1 m³ (322 ft³)

Boeing volume: 8.9 m³ (316 ft³)

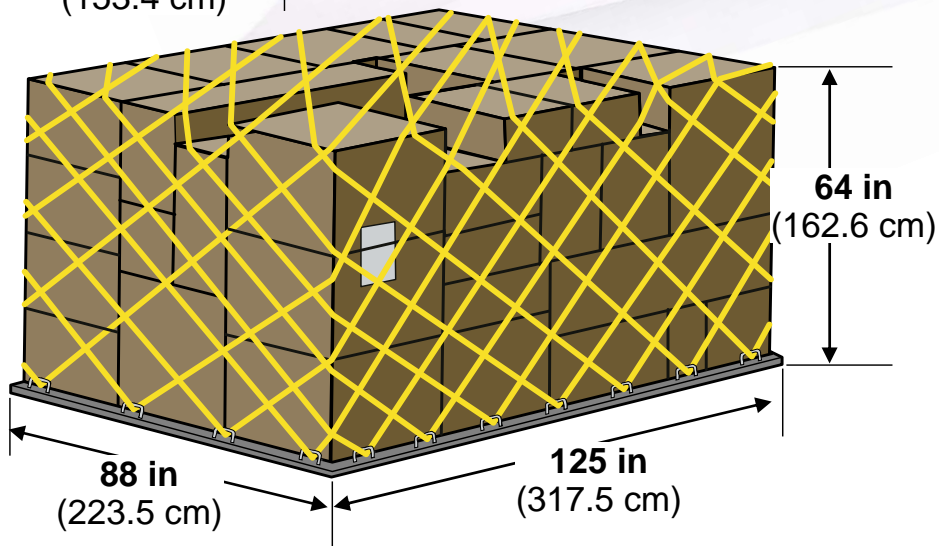

Common designation: LD-7

IATA ULD code: P1P flat pallet with net

Also known as: PAA, PAG, PAJ, PAP, PAX, P1A, P1C, P1D, and P1G

Rate class: Type 5

Description: Universal general-purpose flat pallet for lower holds and main decks.

Suitable for: **Widebody: All aircraft lower holds and main decks**
Standard-body: 707F, 727F, 737F, 757F, DC8F, DC9F main decks

Maximum gross weight: 4,626 kg (10,198 lb)

Tare weight: 105 kg (231 lb)

AS1825 volume: 10.5 m³ (370 ft³)

Boeing volume: 10.7 m³ (379 ft³)

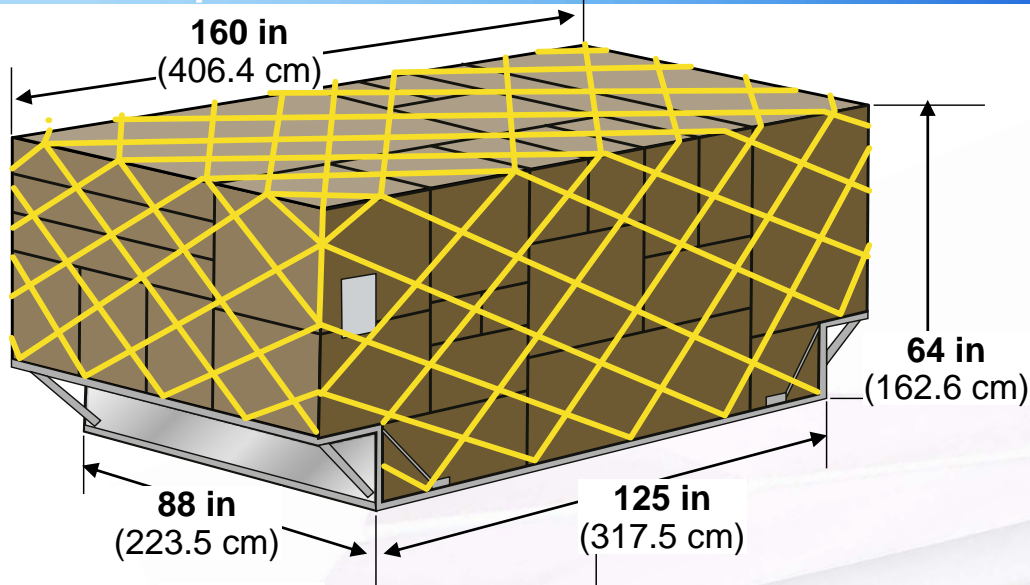

Common designation: LD-7

IATA ULD code: PAD P1P pallet with folding wings and net

Also known as: PAX and P1X

Rate class: Type 5

Description: P1P base with folding wings for overhang.

Suitable for: 747, 777, 787, DC-10, MD-11 lower holds

Maximum gross weight: 5,000 kg (11,023 lb)

Tare weight: 152 kg (335 lb)

AS1825 volume: 14.0 m³ (495 ft³)

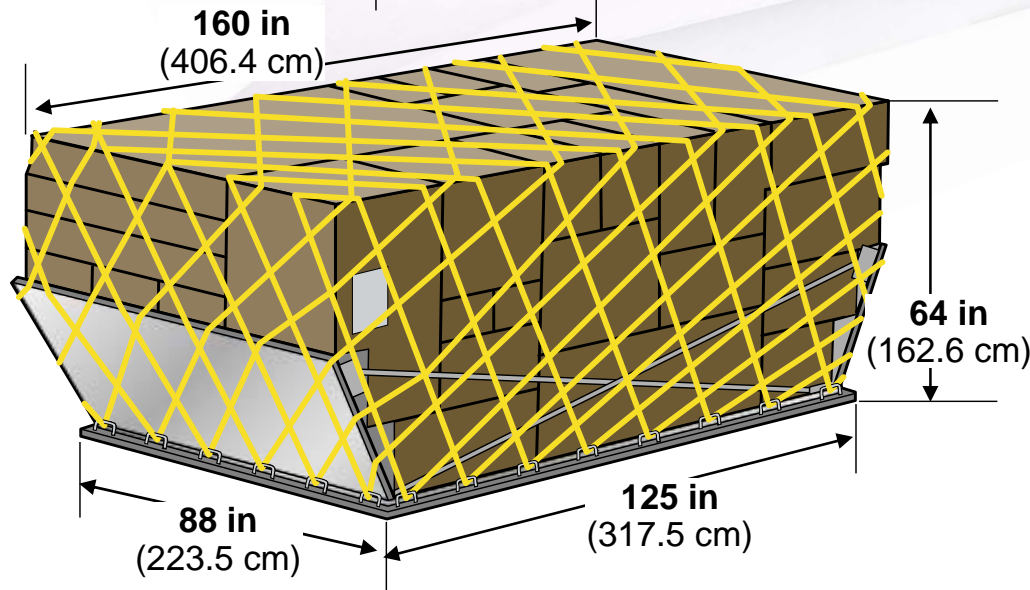

Common designation: LD-7

IATA ULD code: XAW P1P pallet with fixed-angle wings and net

Rate class: Type 5

Description: P1P base with fixed wings for overhang.

Suitable for: 747, 777, 787, DC-10, MD-11 lower holds

Maximum gross weight: 5,000 kg (11,023 lb)

Tare weight: 170 kg (375 lb)

AS1825 volume: 14.0 m³ (495 ft³)

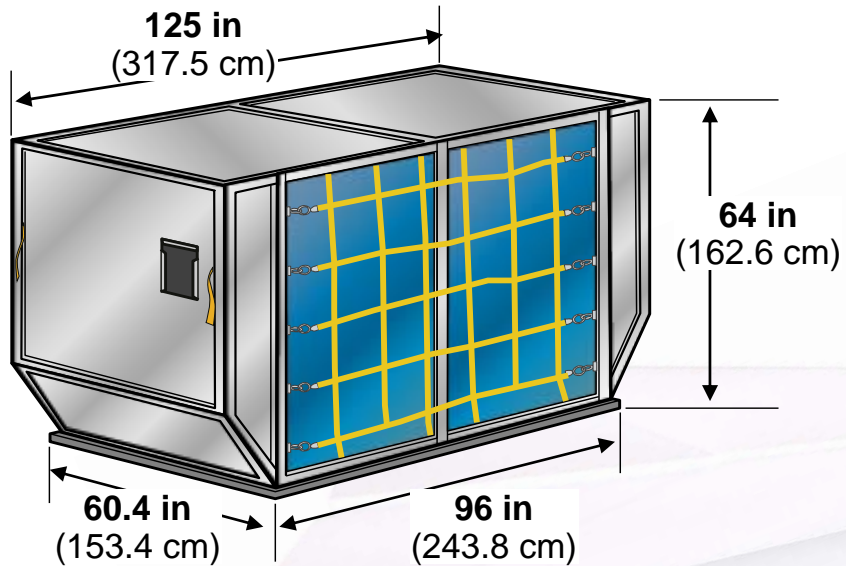

Common designation: LD-8

IATA ULD code: DQF

Also known as: ALE, ALN, DLE, DLF, DQP, and MQP

Rate class: Type 6A

Description: Full-width lower hold container angled at both ends. Door is canvas with built-in door straps.

Suitable for: **767, 787 lower hold**

Door opening: 92 x 62-in (234 x 157-cm)

Maximum gross weight: 2,450 kg (5,401 lb)

Tare weight: 127 kg (280 lb)

AS1825 volume: 7.1 m³ (252 ft³)

Boeing volume: 6.9 m³ (245 ft³)

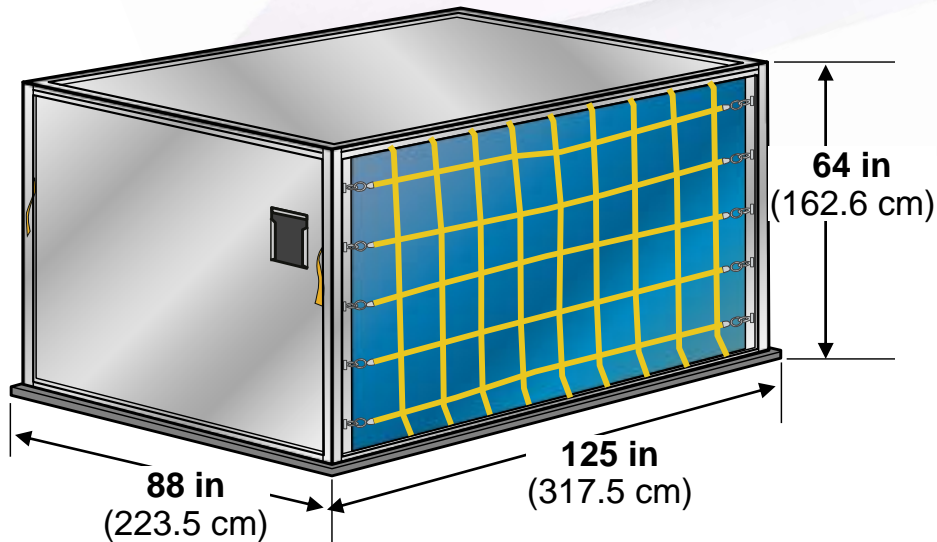

Common designation: LD-9

IATA ULD code: AAP enclosed pallet on P1P base

Rate class: Type 5

Description: General-purpose enclosed container fitted to P1P base. Door is canvas with built-in net door straps, or solid.

Suitable for: **747, 767, 777, 787, DC-10, MD-11 lower hold**

Door opening: 118 x 58 in (300 x 147-cm)

Maximum gross weight: Lower hold, 4,624 kg (10,194 lb); main deck, 6,000 kg (13,227 lb)

Tare weight: Canvas door, 215 kg (473 lb);

solid door, 270 kg (595 lb)

AS1825 volume: 10.8 m³ (381 ft³)

Boeing volume: 10.8 m³ (381 ft³)

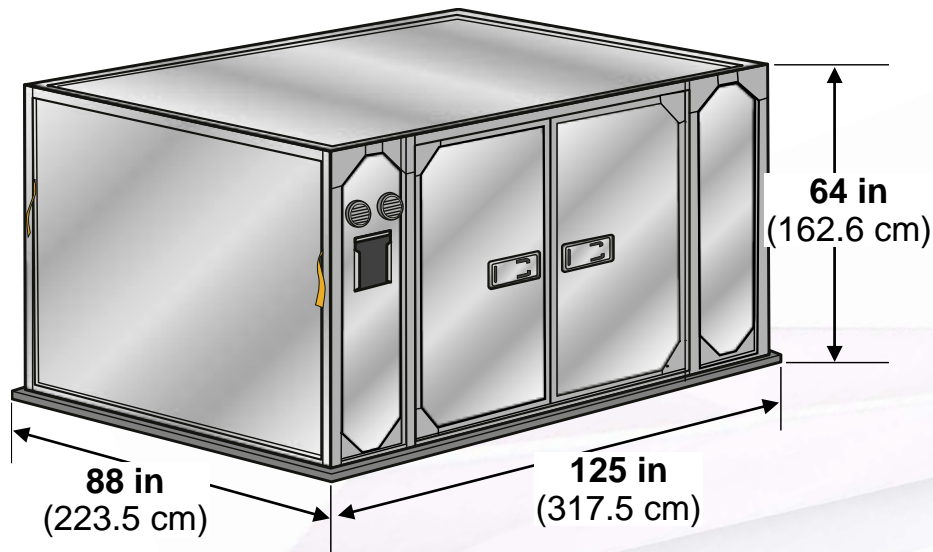

Common designation: LD-9 Reefer

IATA ULD code: RAP cool container on P1P base
Rate class: Type 5
Description: Insulated container with solid door.
Suitable for: 747, 767, 777, 787, DC-10, MD-11 lower hold
Door opening: 85 x 58-in (216 x 147-cm)
Maximum gross weight: Lower hold, 4,626 kg (10,198 lb);
 main deck, 6,000 kg (13,227 lb)
Tare weight: 400 kg (882 lb)
Internal volume: 9.6 m³ (339 ft³)

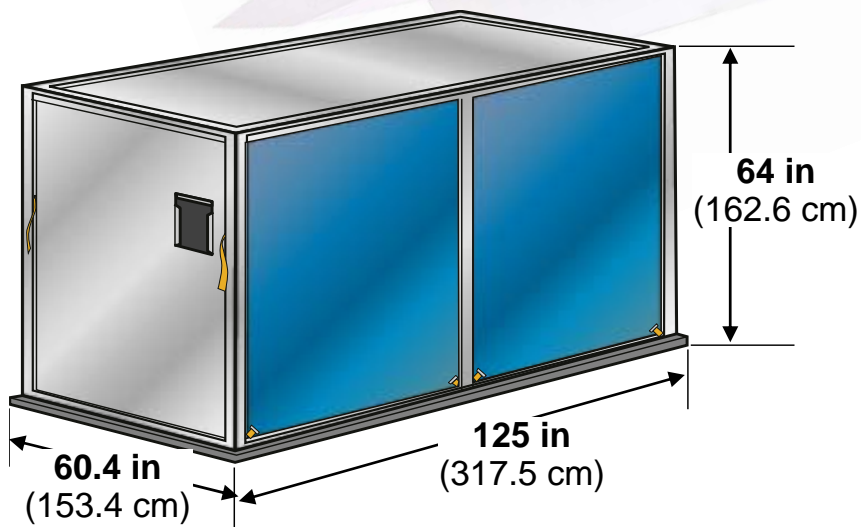

Common designation: LD-11

IATA ULD code: ALP rectangular container
Also known as: ALD, AW2, AWB, AWD, AWZ, DLP, DWB, and MWB. Refrigerated version: RWB, RWD, and RWZ.
Rate class: Type 6
Description: Full-width lower hold container. Door is canvas. Center post swings clear for loading. Refrigerated version has solid door.
Suitable for: 747, 777, 787, DC-10, MD-11 lower hold
Door opening: 120 x 61-in (305 x 155-cm)
Maximum gross weight: 3,176 kg (7,002 lb)
Tare weight: 185 kg (408 lb)
AS1825 volume: 7.4 m³ (262 ft³)
Boeing volume: 7.2 m³ (256 ft³)